



Naboo
reloaded

LAINOX
DEVICE FOR COOKING

NAEB071R

**7 x 1/1 GN
ELECTRIC WITH BOILER**

**AUTOMATIC INTERACTIVE COOKING
TOUCH SCREEN CONTROLS**



LCD 10" Touch Screen

TOUCH SCREEN

10-Inch, LCD, HD, colour, capacitive screen, with "Touch Screen" function choice. The display can be configured based on the user's needs.



MULTILEVEL



JUST IN TIME



AUTOCLIMA



FAST-DRY



SMOKEGRILL



SMOKING



FLAVOURING



ECO VAPOR



TURBO VAPOR



ECO SPEED



ECO WASH



AUTOMATIC WASHING



NABOOK CLOUD



SYNCHRONISATION



REMOTE SERVICE

TECHNICAL DATA

| | | | | | |
|----------------------------|----|--------------------|-------------------------------------|-----------|-----------|
| Capacity | GN | 7 x 1/1 GN | Gas versions nominal heating output | kW / kcal | - / - |
| Distance between layers | mm | 70 | Chamber heating output | kW / kcal | 10 / - |
| Number of meals | | 50 / 120 | Steam heating output | kW / kcal | 7,5 / - |
| External dimensions metric | mm | 875 x 936 x 820 h | Fan power | kW | 0,5 |
| Packing dimensions | mm | 945 x 990 x 1000 h | Power supply voltage | V | 3N AC 400 |
| Weight - Net / Gross | kg | 139 / 157 | Frequency | Hz | 50/60 |
| Total electric power | kW | 10,5 | Consumption | A | 16 |

Special voltages and frequencies on request

COOKING MODES

- ICS (INTERACTIVE COOKING SYSTEM), AN AUTOMATIC COOKING SYSTEM FOR INTERNATIONAL RECIPES INCLUDING THEIR HISTORY, INGREDIENTS, PROCEDURE, AUTOMATIC COOKING PROGRAM AND PLATE PRESENTATION.
- MANUAL COOKING WITH THREE COOKING MODES: FROM 30°C TO 300°C, STEAM FROM 30°C TO 130°C, COMBINATION CONVECTION + STEAM FROM 30°C TO 300°C, WITH INSTANT COOKING START.
- PROGRAMMABLE MODES: POSSIBILITY TO PROGRAMME AND SAVE COOKING METHODS IN AN AUTOMATIC SEQUENCE (UP TO 15 CYCLES) GIVING EACH PROGRAMME ITS OWN NAME, PICTURE AND INFORMATION ON THE RECIPE.
- MULTILEVEL AND JIT MODE.
- MULTILEVEL PLUS: DOUBLING THE MULTI-LEVEL FUNCTION ON EACH SHELF MEANS DOUBLING PRODUCTION CAPACITY.
- AUTOCLIMA® AUTOMATIC SYSTEM FOR MEASURING AND CONTROLLING THE HUMIDITY IN THE COOKING CHAMBER.
- FAST-DRY® SYSTEM FOR QUICK DEHUMIDIFICATION OF THE COOKING CHAMBER.

NABOOK WI-FI CONNECTIVITY

- RECIPE CREATION INCLUDING INGREDIENTS WITH PROCEDURE AND PHOTO.
- DIRECT ACCESS FROM COOKING DEVICE TO LAINOX RECIPE DATABASE WITH OPTIONAL DOWNLOAD.
- MENU CREATION WITH CALORIE COUNT AND LIST OF ALLERGENS WITH LAYOUT FOR CUSTOMISED PRINT OUT.
- FOOD COST CALCULATION OF RECIPES AND SINGLE PORTION MENUS.
- ORGANISATION OF SHOPPING LIST TO EXPORT IN PDF, EXCEL AND WORD FORMAT.
- SYNCHRONISATION OF DEVICES CONNECTED TO THE SAME ACCOUNT.
- HACCP MONITORING.
- REMOTE SERVICE.
- SOFTWARE UPDATE.

OPERATION

- DISPLAY THAT CAN BE CONFIGURED BASED ON THE USER'S NEEDS, BRINGING FORWARD THE PROGRAMMES USED MOST.
- AUTOMATIC "ONE TOUCH" COOKING (ICS).
- ORGANISATION OF RECIPES IN FOLDERS WITH PREVIEW, GIVING EACH FOLDER ITS OWN NAME.
- INTELLIGENT RECOGNITION OF RECIPES IN MULTILEVEL FOLDERS.
- 10" COLOUR SCREEN (LCD, HIGH DEFINITION, CAPACITIVE, WITH "TOUCH SCREEN" FUNCTIONS).
- SCROLLER PLUS KNOB WITH SCROLL AND PUSH FUNCTION FOR CONFIRMING CHOICES.
- AUTOMATIC DOOR OPENING USING THE "OPEN" BUTTON (OPTIONAL)
- INSTANTANEOUS DISPLAY IN ICS COOKING OF THE HACCP GRAPHIC.

CONTROL MECHANISMS

- AUTO REVERSE (AUTOMATIC REVERSE OF FAN ROTATION) FOR PERFECT COOKING UNIFORMITY.
- AUTOMATIC PARALLEL COMPARTMENT AND CORE TEMPERATURE CONTROL, DELTA T SYSTEM.
- AUTOMATICALLY REGULATED STEAM CONDENSATION.
- EASY ACCESS TO PROGRAMMABLE USER PARAMETERS TO CUSTOMISE THE APPLIANCE THROUGH THE USER MENU.
- PROGRAMMABLE DEFERRED COOKING.
- ABILITY TO CHOOSE UP TO 6 FAN SPEEDS; THE FIRST 3 SPEEDS AUTOMATICALLY TRIGGER A REDUCTION IN HEATING POWER. FOR SPECIAL COOKING METHODS, YOU CAN USE AN INTERMITTENT SPEED.
- TEMPERATURE CONTROL AT THE PRODUCT CORE USING PROBE WITH 4 DETECTION POINTS.
- 2 CORE PROBE, A LAINOX EXCLUSIVE.
- CORE PROBE CONNECTION THROUGH A CONNECTOR OUTSIDE OF THE COOKING CHAMBER, WITH THE POSSIBILITY OF QUICKLY CONNECTING THE NEEDLE PROBE FOR VACUUM COOKING AND SMALL PIECES.
- USB CONNECTION TO DOWNLOAD HACCP DATA, UPDATE SOFTWARE AND LOAD/DOWNLOAD COOKING PROGRAMMES.
- POSSIBILITY OF SETTING DEVICE SWITCH-OFF AT THE END OF THE AUTOMATIC WASH PROGRAM.
- PRE-CONFIGURED SN ENERGY OPTIMISATION SYSTEM (OPTIONAL).
- SERVICE PROGRAM: TESTING THE OPERATION OF THE ELECTRONIC BOARD - DISPLAY OF THE TEMPERATURE PROBES - COUNTER FOR OPERATING HOURS OF ALL PRIMARY FUNCTIONS FOR PROGRAMMED MAINTENANCE.
- SELF-DIAGNOSIS BEFORE STARTING TO USE THE EQUIPMENT, WITH DESCRIPTIVE AND AUDIBLE SIGNALLING OF ANY ANOMALIES.
- ECOSPEED - BASED ON THE QUANTITY AND TYPE OF PRODUCT, THE OVEN OPTIMISES AND CONTROLS THE ENERGY OUTPUT, MAINTAINING THE BEST COOKING TEMPERATURE AND AVOIDING FLUCTUATIONS.
- ECOVAPOR - WITH THE ECOVAPOR SYSTEM, THERE IS A NET REDUCTION IN WATER AND ENERGY CONSUMPTION DUE TO THE AUTOMATIC CONTROLS OF THE STEAM SATURATION IN THE COOKING CHAMBER.
- TURBOVAPOR - WITH THE TURBOVAPOR SYSTEM IT AUTOMATICALLY PRODUCES THE IDEAL LEVEL OF STEAM TO COOK "TOUGH" PRODUCTS LIKE EGG PASTA OR ASPARAGUS, TURNIP GREENS AND CHARD, WHICH ARE NOTORIOUSLY FIBROUS VEGETABLES.

CONSTRUCTION

- PERFECTLY SMOOTH, WATERTIGHT CHAMBER
- DOOR WITH DOUBLE TEMPERED GLASS WITH AIR CHAMBER AND INTERIOR HEAT-REFLECTING GLASS FOR LESS HEAT RADIATION TOWARDS THE OPERATOR AND GREATER EFFICIENCY
- INTERNAL GLASS THAT FOLDS TO OPEN FOR EASY CLEANING
- HANDLE WITH LEFT OR RIGHT HAND OPENING
- ADJUSTABLE HINGE FOR OPTIMAL SEAL
- DEFLECTOR THAT CAN BE OPENED FOR EASY FAN COMPARTMENT CLEANING
- IPX5 PROTECTION AGAINST SPRAYS OF WATER

ELECTRIC HEATING SYSTEM

- COOKING COMPARTMENT HEATING ELEMENTS OF ARMoured INCOLOY 800 TYPE

STEAM GENERATOR

- AISI 304 FULLY INSULATED STEAM GENERATOR
- AUTOMATIC BOILER PRE-HEATING
- DAILY AUTOMATIC BOILER DRAINING (TEMPERATURE OF DRAINED WATER BELOW 60°C) AND RINSING

NAEB071R

- ALARM IN CASE OF BOILER DE-SCALING REQUIRED
- BOILER SEMI-AUTOMATIC DE-SCALING PROGRAM
- CAL-OUT SYSTEM TO PREVENT SCALE BUILD-UP WITHIN THE BOILER, AS STANDARD

SAFETY FEATURES

- COOKING COMPARTMENT SAFETY THERMOSTAT
- COOKING COMPARTMENT SAFETY DEVICE FOR PRESSURE BUILT-UP AND DEPRESSION
- FAN MOTOR THERMIC PROTECTION
- MAGNETIC DOOR SWITCH
- LACK OF WATER DISPLAYED ALARM
- SELF-DIAGNOSIS AND FAULT DISPLAY
- COMPONENT COOLING SYSTEM WITH OVERHEAT DISPLAY CONTROL
- BOILER SAFETY THERMOSTAT
- BOILER WATER LEVEL PROBES
- BOILER PROBE TO CHECK BOILER COMPLETELY EMPTY

CLEANING AND MAINTENANCE

- AUTOMATIC CLEANING SYSTEM LCS (LIQUID CLEAN SYSTEM) WITH BUILT-IN TANK AND AUTOMATIC DISPENSING (COMBICLEAN LIQUID CLEANSER IN 100% RECYCLABLE CARTRIDGES. SUPPLIED WITH 1 LIQUID CLEANSER CARTRIDGE CDL05 - 990 GR.).
- CALOUT DESCALING SYSTEM, THAT PREVENTS THE FORMATION AND ACCUMULATION OF LIMESCALE IN THE BOILER, WITH BUILT-IN TANK AND AUTOMATIC DISPENSING (CALFREE LIQUID DESCALER, IN 100% RECYCLABLE CARTRIDGES. SUPPLIED WITH 1 LIQUID DESCALER CARTRIDGE CCF05 - 990 GR.).
- MANUAL CLEANING SYSTEM WITH RETRACTABLE HAND-HELD SHOWER.

STANDARD EQUIPMENT

- AUTOMATIC CLEANING SYSTEM LCS - SUPPLIED WITH 1 LIQUID CLEANSER CARTRIDGE CDL05 - 990 GR.
- CALOUT DESCALING SYSTEM FOR MODELS WITH BOILER - SUPPLIED WITH ANTI-SCALE PRODUCT
- MULTIPOINT CORE PROBE Ø 3 MM.
- BUILT-IN AND RETRACTABLE HAND SHOWER WITH TAP
- WI-FI CONNECTION
- USB CONNECTION

OPTIONAL - TO BE REQUESTED WHEN ORDERING OVEN

- **NAA:** AUTOMATIC DOOR OPENING - NOT COMPATIBLE WITH HANDLE - NOT AVAILABLE WITH RIGHT HINGED DOOR
- **NPS:** OPPOSITE HINGED DOOR
- **APDS:** DOUBLE RELEASE DOOR OPENING- NOT AVAILABLE WITH RIGHT HINGED DOOR
- **NSG:** SMOKEGRILL - 3 IN 1 - BARBECUE SYSTEM / SMOKING / FLAVOURING
- **NETH:** EXTRA CHARGE FOR ETHERNET CONNECTION
- **NPK:** CONFIGURATION FOR CONNECTION TO EXTRACTION HOOD
- **SN:** EXTRA CHARGE FOR ENERGY SAVING SYSTEM CONNECTION - ELECTRIC MODELS ONLY
- **NSS071:** EXTRA CHARGE FOR REMOVABLE RACK NSE071 + COMPULSORY FRAME NTL071
- **NSS564:** EXTRA CHARGE FOR PASTRY VERSION REMOVABLE RACK NSE564 + COMPULSORY FRAME NTL071
- **NSP664:** EXTRA CHARGE FOR PASTRY VERSION SHELF RACKS NGP664
- **DSP:** DISPLAY-CONTROL PANEL PROTECTION

EXTRA ACCESSORIES THAT CAN BE INSTALLED FOLLOWING PURCHASE

- **KSC180:** MULTIPOINT CORE PROBE FOR LARGE ITEMS Ø 3 MM, PIN LENGTH 180 MM.
- **KSA001:** NEEDLE CORE PROBE Ø 1 MM.
- **KSM002:** MULTIPROBES SYSTEM, 2 MULTIPOINT CORE PROBES. Ø 3 MM
- **NFX01:** FAT FILTER
- **KP004:** SET OF FEET - 150 MM H
- **RP004:** CASTER KIT, 2 WITH BRAKE
- **NSR071:** STAINLESS STEEL FLOOR STAND - FULL AISI 304
- **NSR071S:** STAINLESS STEEL FLOOR STAND FOR INSERTION OF THE BLAST CHILLER MOD. 050-051, OR FOR OVEN INSTALLATION WITH HOOD - FULL AISI 304
- **NPT071:** SIDE RUNNERS - FIXED TO FLOOR STAND - FULL AISI 304
- **NAN071:** NEUTRAL CABINET WITH DOORS AND SIDE RUNNERS - FIXED TO FLOOR STAND - FULL AISI 304
- **NAL071:** NEUTRAL CABINET WITH DOORS - FIXED TO FLOOR STAND - FULL AISI 304
- **RP04:** CASTER KIT FOR FLOOR STANDS, 2 WITH BRAKE
- **CCE:** COLLECTOR FOR EXTERNAL CONNECTION - Ø 150 MM
- **NSE071:** REMOVABLE RACK - TO BE USED WITH COMPULSORY FRAME
- **NSE564:** REMOVABLE RACK - TO BE USED WITH COMPULSORY FRAME - PASTRY VERSION
- **NGP664:** PAIR OF SHELF RACKS 600 X 400 - PASTRY VERSION
- **NPA071:** STAINLESS STEEL HEAT SHIELD FOR THE UNIT SIDE PANEL

The data reported in this document is to be considered non-binding. The company reserves the right to make changes at any time, without prior notice

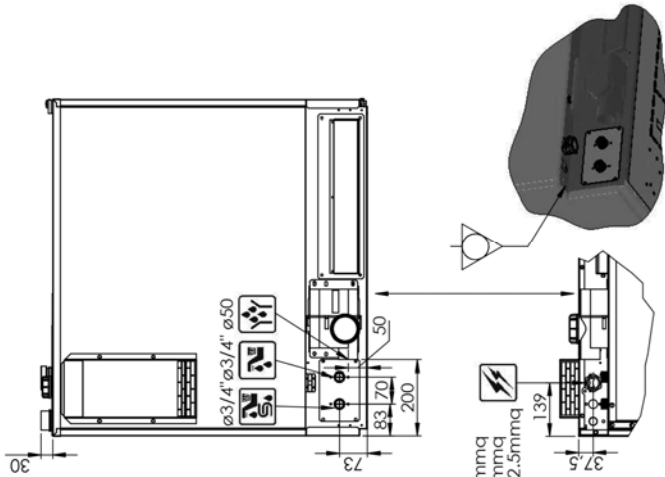
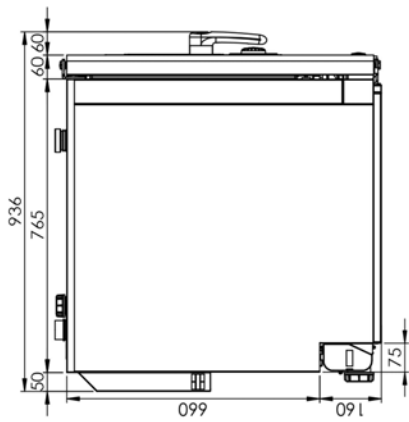
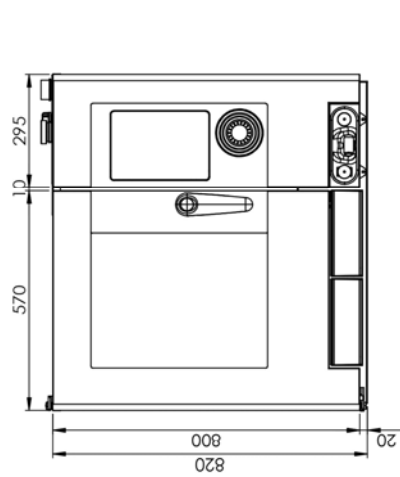
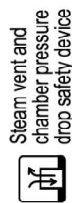
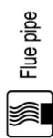

AC 230V n°3x10mmq
3AC 230V n°4x4mmq
3NAC 400V n°5x2.5mmq

